

REVISIONS				
ZONE	REV.	DESCRIPTION	DATE	APPROVED
ALL	A	INITIAL RELEASE	4/24/2018	BEN STAAL

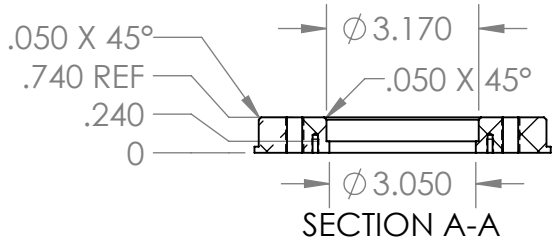

NOTE: HOLE PATTERN REPEATS EVERY 120°

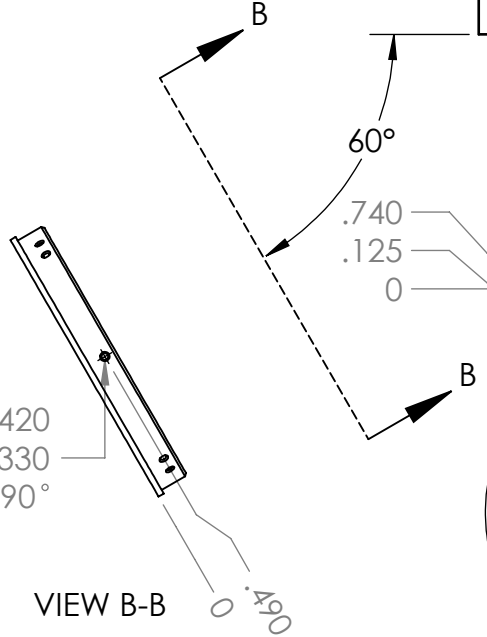
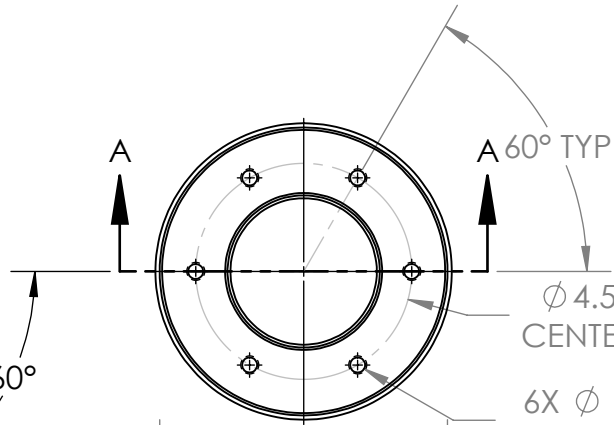
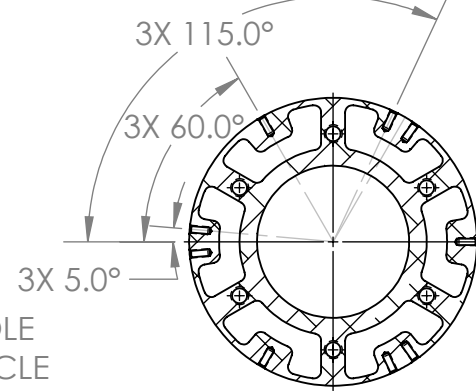
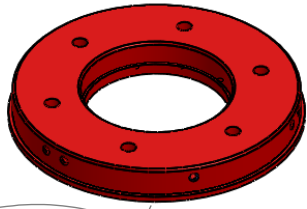

9X Ø .136 ∇ .420
8-32 UNC ∇ .330
 \surd Ø .200 X 90°

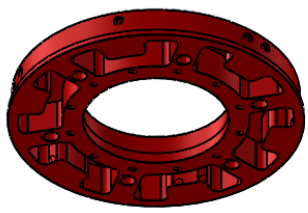

	NAME	DATE	PROJECT:	
DRAWN	BEN STAAL	4/24/2018	L3 CERT ROCKET	
APPROVED	BEN STAAL		TITLE:	
UNLESS OTHERWISE SPECIFIED: DIMENSIONS ARE IN INCHES			THRUST PLATE	
TOLERANCES: TWO PLACE DECIMAL: \pm .01 THREE PLACE DECIMAL \pm .005 ANGULAR: MACH \pm .2° BEND \pm .5°			SIZE	DWG. NO.
MATERIAL AL, 6061-T6			A	1-002
FINISH ANODIZE PER MIL-A-8625 TYPE II, CLASS 2, RED			REV	A
DO NOT SCALE DRAWING			SCALE: 1:4	WEIGHT: 0.89
			SHEET 1 OF 2	

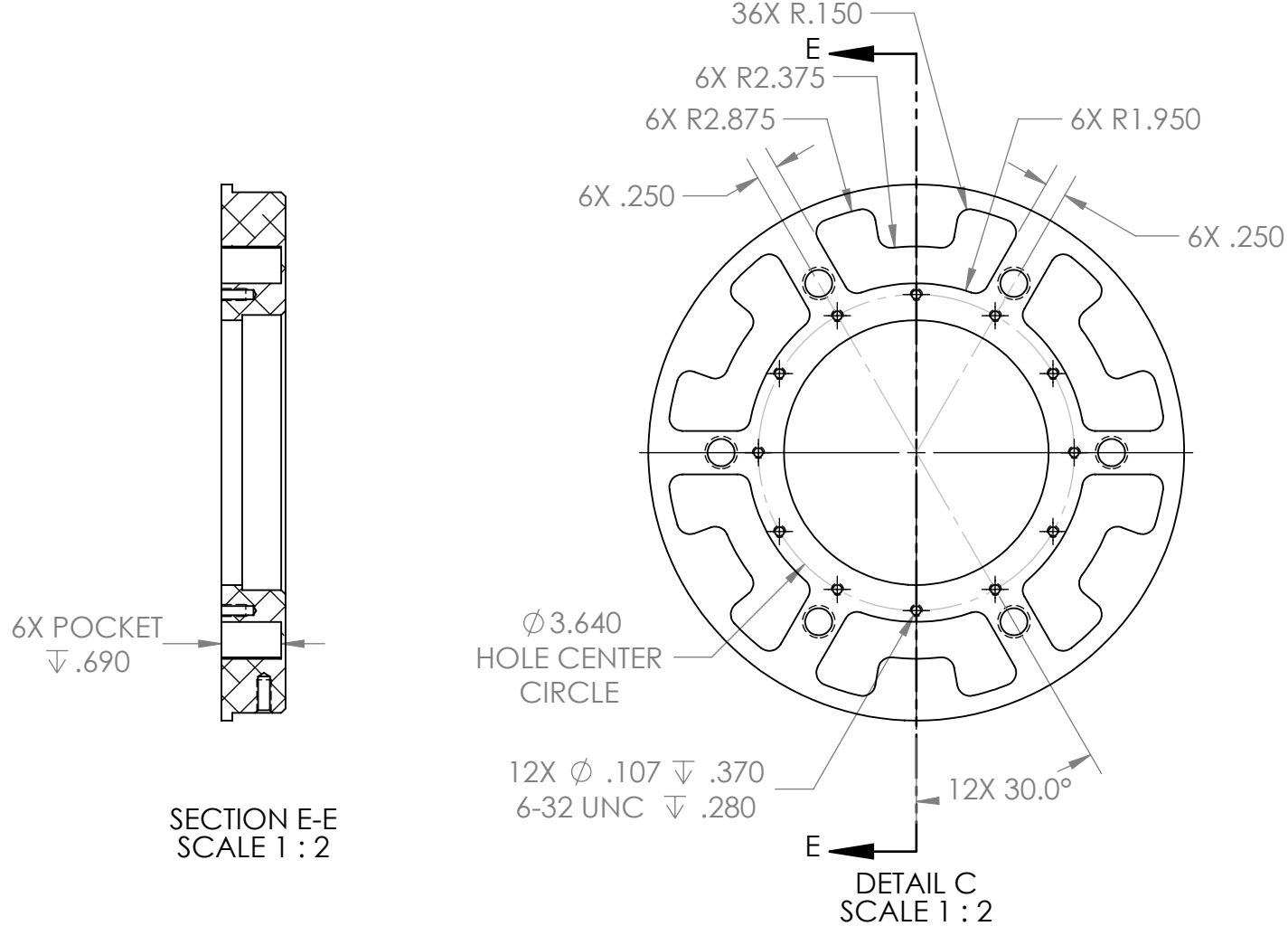

	NAME	DATE	PROJECT:	
DRAWN	BEN STAAL	4/24/2018	L3 CERT ROCKET	
APPROVED	BEN STAAL		TITLE:	
UNLESS OTHERWISE SPECIFIED: DIMENSIONS ARE IN INCHES			THRUST PLATE	
TOLERANCES: TWO PLACE DECIMAL: ±.01 THREE PLACE DECIMAL ±.005 ANGULAR: MACH ±.2° BEND ±.5°			SIZE	DWG. NO.
			A	1-002
			SCALE: 1:4	WEIGHT: 0.89
			SHEET 2 OF 2	
			REV	A