

REVISIONS				
ZONE	REV.	DESCRIPTION	DATE	APPROVED
ALL	A	INITIAL RELEASE	4/24/2018	BEN STAAL

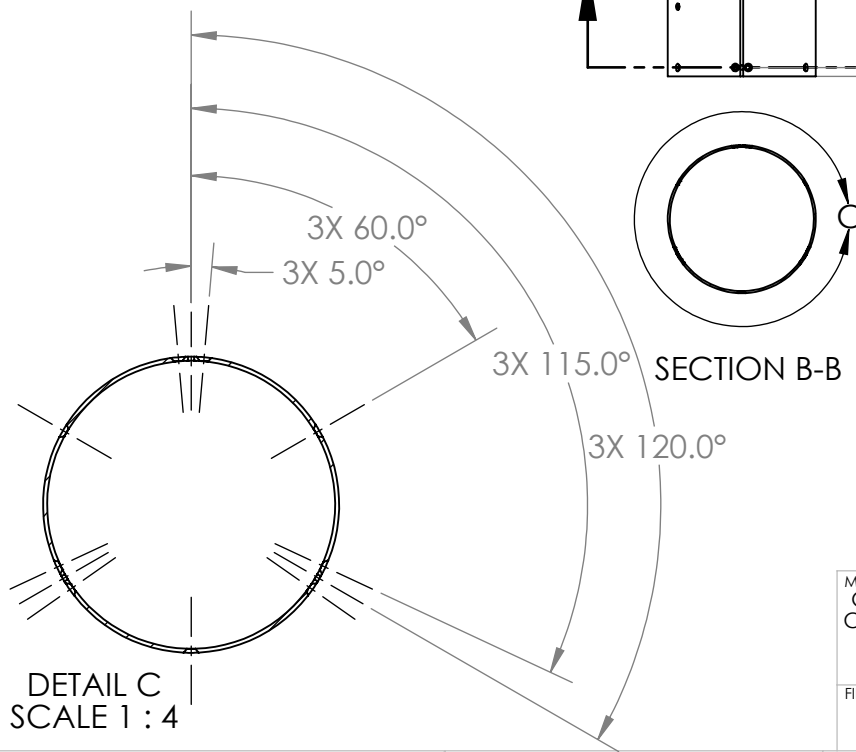

MATERIAL  
G12 FIBERGLASS, MAD  
COW SKU: FT60-600-RED

FINISH

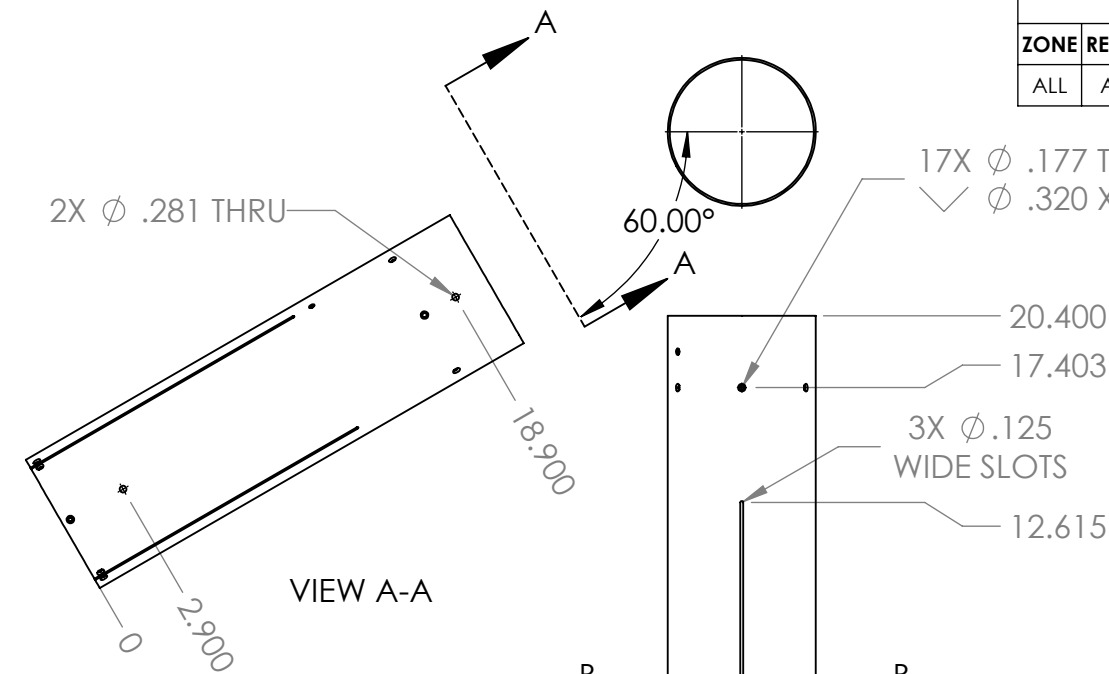
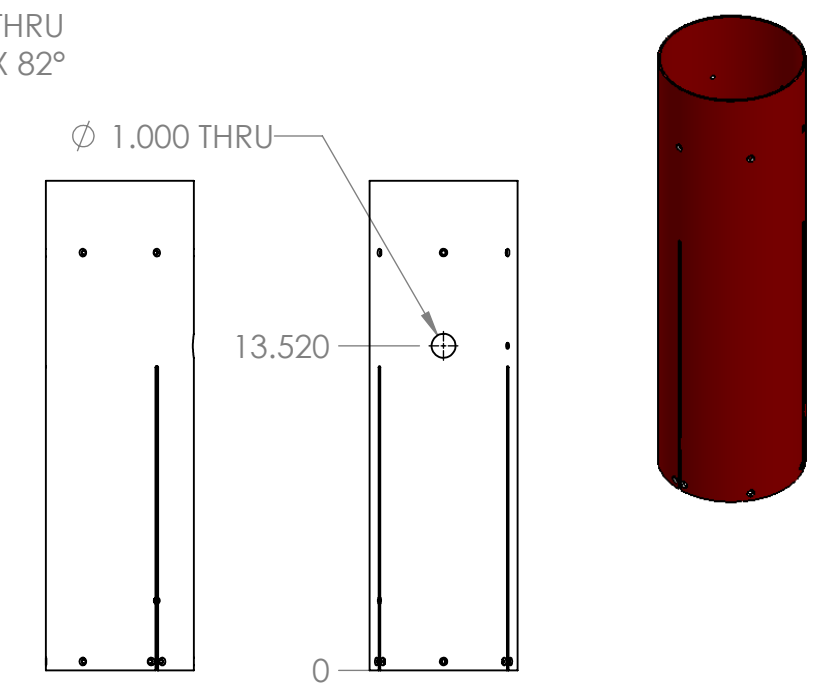

	NAME	DATE	PROJECT:	
DRAWN	BEN STAAL	4/24/2018	L3 CERT ROCKET	
APPROVED	BEN STAAL		TITLE:	
UNLESS OTHERWISE SPECIFIED: DIMENSIONS ARE IN INCHES			FIN CAN SECTION BODY TUBE	
TOLERANCES: TWO PLACE DECIMAL: ±.01 THREE PLACE DECIMAL ±.005 ANGULAR: MACH ±.2° BEND ±.5°			SIZE	REV
DO NOT SCALE DRAWING			DWG. NO. <b>A</b> 1-011	<b>A</b>
			SCALE: 1:8	WEIGHT: 2.51
			SHEET 1 OF 1	